

# Spartan GoCam™ Cellular Camera



## User Manual



Important: Please read this manual carefully before using your camera.

Thank you for choosing the Spartan GoCam. This manual will help you get the most out of your new device. You will also find this manual, other technical articles and more information about your camera and using Premium service at:  
[www.spartancamera.com](http://www.spartancamera.com).

If you experience any difficulties operating this product, **please do not return it to the store**. Call Tech Support at 770-582-0004 9 AM – 6 PM EST, Monday – Friday or email us at [support@spartancamera.com](mailto:support@spartancamera.com).

## Table of Contents

Package Contents .....	1
Camera Body and Ports .....	1
Camera Buttons.....	2
Activate Cellular Service.....	2
AT&T™ SIM Card .....	2
Spartan Camera SIM Card .....	2
Set Up the Camera.....	2
Connect the Camera to the AT&T™ Network .....	2
Premium vs. Auto .....	3
Premium Setup.....	3
Overview.....	3
Add Camera to the Web Portal .....	4
Complete Camera Setup on the Portal .....	4
Test the Camera and Portal .....	5
Install and Set Up the Mobile App.....	5
Auto Setup.....	5
Complete Physical Camera Setup .....	6
Camera Settings.....	6
Test the Camera .....	8
Photo, instant send mode .....	8
Photo, daily report or send mode off.....	8
Video.....	8
Access Photos or Videos.....	8
View a Photo.....	8
Watch a Video.....	8
Delete Photo or Video.....	8
Manual Firmware Update .....	8
Technical Specifications.....	9
Manufacturer Limited Warranty.....	9
Terms and Conditions .....	9
Shipping.....	9
Proof of Purchase or Proof of Warranty Coverage.....	9
Exclusions and Limitations.....	10
Unclaimed Items .....	10
Camera Repair .....	10
Privacy Policy .....	10
How Do We Use Your Email Address? .....	11

Do We Use Cookies? .....	11
Security Measures.....	11
Retention and Deletion.....	11
Terms of Use .....	11
About Us .....	11
Our Customers.....	11
Membership Responsibilities.....	11
Cost and Pricing.....	12
Content Limits .....	12
Content & Privacy.....	12
Limits on Use .....	13
Other Important Guidelines .....	13
Things to Keep in Mind.....	13
Image Delivery .....	14

## Package Contents

Camera	1
Antenna	1
SIM card	1
Mounting strap	1
USB cable	1
Quick Start Guide	1

## Camera Body and Ports

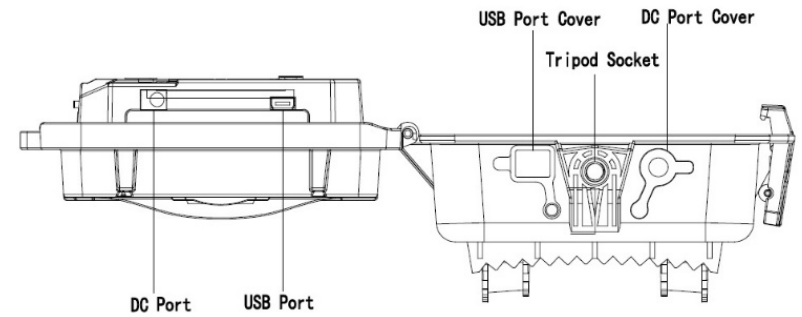
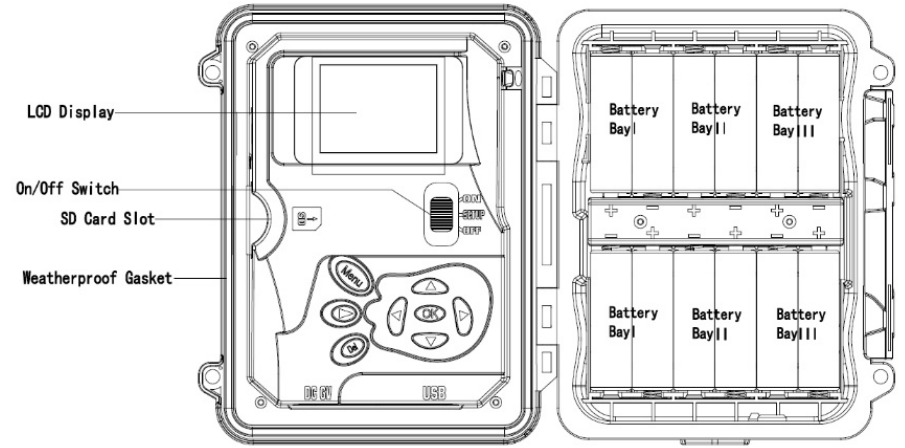
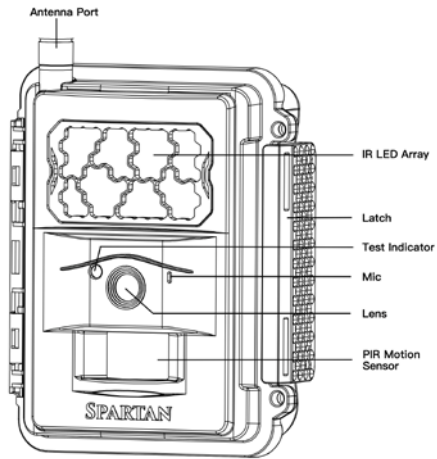

## Camera Buttons

- **Menu:**
  - *Preview* mode: enter the *Setup* menu.
  - *Setup* mode (menus): Go back one menu level. (If in a submenu, return to the main menu. If at the main menu, exit *Setup* mode.)
  - *Playback* mode: display the *Delete* menu so you can choose to *Del One* or *Del ALL*.
- **Arrows ▲▼◀▶:**
  - *Setup* mode: move between menu items, change values.
  - *Playback* mode: ◀▶ move through photos/videos
  - *Playback* mode, photos: ▲ zoom in, ▼ zoom out. When zoomed in, press **OK** then use ▲▼◀▶ to pan the image.
- **OK:**
  - *Menu* mode: save parameter settings.
  - *Preview* mode: take a photo or start recording a video manually.
  - *Playback* mode, videos: play/pause video.
- **Playback button ►:** In the preview window, switch between *Playback* and *Preview* modes
- **Del:**
  - *Menu* mode: when entering parameters, works as a backspace key, deletes the character to the left.
  - *Playback* mode: delete the current photo/video.
- **Shortcuts in *Preview* mode:**
  - ▲ selects *Video* mode.
  - ▼ selects *Camera* mode.
  - **OK** takes a picture or records a video manually.
- **Mode (Power) Switch:** ON at top. **SETUP** in the middle. OFF at the bottom.

## Activate Cellular Service

Cellular service is required if you want to have photos delivered to email and/or your mobile device, regardless of whether you use Premium or Auto service for photo delivery. Cellular service enables the camera to send photos.

A separate plan is required for each camera. Coverage and service is not available in all areas.

## AT&T™ SIM Card

If your SIM card is labeled BUYSESSION, use your web browser to go to [www.att.com/buyasession](http://www.att.com/buyasession) to purchase an AT&T DataConnect Pass.

## Spartan Camera SIM Card

If your SIM card is labelled SPARTANCAMERA:  
Use your web browser to go to [www.spartancamera.com](http://www.spartancamera.com).  
Create an account and log in.  
Go to SHOP > BUY AT&T SERVICE.  
Follow the steps to activate your data service.

Record your camera's telephone number: \_\_\_\_\_

## Set Up the Camera

1. With the power switch **OFF**, insert batteries into the battery compartment. Use 12 (recommended), 8, or 4 (emergency, left 2 columns) 1.2-1.5v AA batteries.

The following types of batteries can be used:

- High-performance alkaline
- Lithium
- Rechargeable NiMH

For longer battery life, you can connect the camera to a 6V external battery (with or without solar panel) that is designed to be used with trail cameras.

2. Insert the SIM card.
3. Insert an *unlocked* SD card (up to 32 G, class 10 recommended) into the SD card slot. Refer to the card symbol on the case for proper orientation.
4. With the rubber gasket between the base of the antenna and the antenna jack on the top of the camera, screw the antenna onto the antenna jack. The rubber gasket must be in place to prevent leaks. Make sure the antenna is screwed in all the way but be careful not to over-tighten it.

## Connect the Camera to the AT&T™ Network

1. Slide the power switch to the **SETUP** position. The camera will enter *Preview* mode. The screen will display *Searching network...*, then *AT&T* will appear at center top of the screen and the signal strength bars will show in the top right corner.

2. Press the **Menu** button to access the *Setup* menu.
3. Format the SD card: navigate to the *System* tab, then scroll down to *Format*, press the **OK** button, select *Yes*, and press the **OK** button again.  
*It is very important that you format the SD card in the camera before using it and it is a good idea to format it again ever so often.*
4. Decide whether you will be using Premium service (recommended, free to try for the first month) or Auto service by reviewing the information in the next section, *Premium vs. Auto*. If you will be using Premium, go to *Premium Setup* on page 3. If you will be using Auto, go to *Auto Setup* on page 5.

### Premium vs. Auto

Before you finish setting up your camera, you must decide whether you will use Premium or Auto service. The following table should help you decide. Every camera comes with one free month of Premium service, which does not require that you subscribe to anything or provide any sort of payment information and will not auto renew unless you purchase credits for service. You are encouraged to try Premium, no strings attached, to see how you like it. Additional months of Premium service cost \$3-4/month, depending on how many credits (months) you buy at a time.

Feature	Premium with app <sup>1</sup>	Premium without app	Auto
<b>Change settings</b>			
All (using portal)	Yes	Yes	(only by using camera's internal options)
All (using app)	Yes	N/A	
<b>Picture delivery</b>			
Portal	Yes	Yes	N/A
App	Yes	N/A	N/A
Email <sup>2</sup>	Yes (up to 4)	Yes (up to 4)	Yes (1)

Feature	Premium with app <sup>1</sup>	Premium without app	Auto
<b>Thumbnail size</b>			
Normal (640 * 480)	Yes	Yes	Yes
Large (1280 * 960)	Yes	Yes	No
<b>Video delivery</b>			
320 * 240 or 1024 * 576 (5 sec or 10 sec)	Yes	Yes	No

Feature	Premium with app <sup>1</sup>	Premium without app	Auto
<b>Daily status report</b>			
Portal	Yes	Yes	N/A
App	Yes	N/A	N/A
Email <sup>2</sup>	Yes	Yes	Yes
<b>Scheduled events (up to 9 additional status reports, scheduled pictures)</b>			
Portal	Yes	Yes	N/A
App	Yes	N/A	N/A
Email <sup>2</sup>	Yes	Yes	No
<b>Request HD photo</b>			
Portal	Yes	Yes	N/A
App	Yes	Yes	N/A
Photos stored on server for 30 days	Yes	Yes	NA
<b>Firmware update</b>			
Over The Air (OTA via portal)	Yes	Yes	N/A
Manually (SD card)	Yes	Yes	Yes
Cost per month	\$3-4	\$3-4	\$0

<sup>1</sup>Android and iOS versions of the app are available for smart phones and tablets with newer versions of the OS.

<sup>2</sup>Email refers to regular email addresses as well as to your device's phone number in your carrier's email format (e.g., 5555551212@vzwpix.com or 5555551212@mms.att.net). Note: While you can use your phone number email address, that is no longer recommended because some carriers have begun blocking some MMS messages and senders, which can result in your not receiving pictures from your camera. Spartan Camera does not guarantee the delivery of emails.

**We recommend that you set up, test, and use your camera at home before deploying it, especially if this is new technology to you.**

### Premium Setup

#### Overview

Here is a brief overview of the steps to set up your camera and get it working with Premium:

- Register your camera by having it connect to the web portal.
- Add your camera to your account on the web portal.

- Specify the camera settings using the web portal.
- Install the app on your mobile device.

These are the minimum steps to have premium completed and working. Photos from your camera will be uploaded and stored on your Spartan Camera account for 30 days. Important: Each night, the oldest photos (31 days and older) will be automatically purged from the server.

This is a more detailed list of steps to complete Premium setup:

### Add Camera to the Web Portal

1. Using a web browser on your computer or phone, go to [www.spartancamera.com](http://www.spartancamera.com).
2. Sign in to your account. If you don't already have an account, register for one, then sign in.
3. To set your time zone:
  - a. From the main menu, *MY ACCOUNT > ACCOUNT OPTIONS*.
  - b. Select the region and the time zone, then click the *Update* button.
4. To add your camera:
  - a. From the main menu, select *MY CAMERAS > MANAGEMENT*.
  - b. Click the *Add New Camera* button.
  - c. Move the camera switch to *SETUP* and when you have a signal, press the **Menu** button then select the *Wireless* menu.
  - d. Verify that *Send Mode* is *Instant* and the *Send Via* is *Premium*. Press **OK** after making any changes.
  - e. Select *Register Camera*, press **OK**, and wait several seconds. If registration is successful, the camera screen will show your Module ID (IMEI) and the registration code. If registration is not successful, repeat this step.
  - f. On the portal *Add New Camera* page, type a description for the camera that will help you to identify it. This is especially important if you have more than one. If you want the cameras listed in a particular order in the phone app, assign names that will sort in alphabetical/numerical order (e.g., 01 SE corner, 02 NE corner, etc.)
  - g. Input both the Module ID and the Registration Code.
  - h. Check the box to agree to the terms of use and privacy policy.
  - i. Click the *Add this Camera* button.
5. If you input the values correctly, you will return to the *CAMERA MANAGEMENT* page on the web portal.
6. Send a Test Picture: in *Preview* mode, press **OK** to take a picture then **OK** again to send it.
7. If you can see the picture on the *MY CAMERAS > CAMERA MANAGEMENT* or *MANAGE PHOTOS* page, Premium service is working.

All you need to do is to customize the setup for your particular needs by updating camera settings, adding email contacts, etc.

8. We strongly recommend that you finish setting up your camera on the portal and setting up the mobile app if you are going to use it before you deploy the camera but if you wish to skip those steps, go to *Complete Physical Camera Setup* on page 6.

### Complete Camera Setup on the Portal

Complete these steps on the portal to finish the Premium setup.

1. Verify that you have credits on your account: Select *MY ACCOUNT > PREMIUM CREDIT HISTORY* and verify that you have at least one credit. Adding a brand new camera will add a free credit to your account.
2. Change your camera settings: *MY CAMERAS > CAMERA SETTINGS*
  - a. Set the *region* and *time zone*. The time zone must be set in order for your camera to function properly.
  - b. Choose and set all the settings you want to use.
  - c. It is recommended that you set several scheduled events, either status reports or photos. There are nine available events for you to set, plus the default daily status report that you can set the time for. You will probably want to use most or all of available events at least for status reports throughout the day so that you don't have to wait too long to get requested HD photos or video downloads.

You may want to set some scheduled events to take photos at specific times (e.g., 9 AM and 9 PM so that you will get at least two pictures every day). This is especially useful if your camera is in a low-traffic area. The scheduled photos are reassurance that your camera is still there and is still working.

  - d. When you are done, click *Schedule a Settings Update*.
  - e. To force the camera to contact the server and update settings, take and send a manual photo (in *SETUP* mode, **OK**, **OK**. Watch the screen and after the photo is sent, you will see a message that the settings have been updated.)
3. Update the camera firmware if your camera's firmware is not the latest version:
  - a. On the portal, select *MY CAMERAS > FIRMWARE UPDATE*.
  - b. Compare the date of the firmware version listed for your camera to the date of the latest version.
  - c. If the latest version is more recent than the one on your camera, click *Update*.
  - d. Take and send another manual photo. After the screen says the photo has been sent, it will indicate that it is downloading and updating the FW, then it will restart and come back up in setup mode.

## Test the Camera and Portal

1. Turn your camera on and walk test it or set it for time-lapse mode with a short trigger interval.
2. View the photos on the web portal:
  - a. Select *MY CAMERAS > CAMERA MANAGEMENT* or *MANAGE PHOTOS*.
  - b. Refresh the browser periodically or check your email.
3. Request a status report:
  - a. While you are testing the camera, select *MY CAMERAS > MANAGEMENT*.
  - b. Click the *Manage Camera* dropdown then click *Request Status*.
  - c. Refresh the browser periodically. The pending request is listed under *Pending Actions* until it's complete, then it will be listed if you drop down *COMMAND HISTORY*. You will also receive a status report via email if you entered an email address for *Email to Send Status Reports* on the *MY CAMERAS > DELIVERY OPTIONS* page.
4. If you don't plan to use the mobile app or you want to set it up later, go to *Complete Physical Camera Setup* on page 6.

## Install and Set Up the Mobile App

Overview: The following basic steps will get the app working on your device.

- On the web portal, specify admin and guest access codes.
  - On your mobile device, download and install the app from either Google Play Store or Apple App Store.
  - Using the mobile app, authenticate to connect the app to your Spartan Camera account.
1. On the web portal, set up both admin and guest access codes:
    - a. Select *MY CAMERAS > MOBILE ACCESS*.
    - b. Enter an *Admin Access Code* and (optionally, if you want to share pictures but not camera control with guests) a *Guest Access Code*. You can use different admin and guest access codes for different cameras or groups of cameras if you want to share access with different groups of people. Most people will probably want to use the same admin code for all their cameras.
    - c. Click the *Update* button.
    - d. Make a note of your Account ID, the Admin Access Code and the Guest Access Code.  
Account ID: \_\_\_\_\_  
Admin Access Code: \_\_\_\_\_  
Guest Access Code: \_\_\_\_\_

2. On your mobile device, go to the appropriate app store and search for the "Spartan Camera management" app (from Frontier Pursuits Technology).



3. Download and install the app.
4. Launch the Spartan Camera mobile app. Read the quick tip, then close it.
5. To connect the app to your Spartan Camera account:
  - a. From the menu, tap *Camera Management*.
  - b. Tap + to open the authentication dialog.
  - c. Enter the Account ID and the Access Code (the admin code for your phone, guest code for people who you don't want controlling the camera).
  - d. Tap *Add*.
6. Return to the main screen. If your phone is connected to WiFi, your pictures should appear.
7. Check the following settings and change if appropriate:
  - a. Tap the *Menu* button.
  - b. Tap *Mobile Settings*.
  - c. Under *When New Photo is Available*, you will probably want *Automatically Download* set to ON and *Download Only When WiFi is Available* set to OFF. If the WiFi setting is OFF, photos and videos will download whether you are on WiFi or not, but be aware that downloads will use your device's data allowance if WiFi is not available. Thumbnails typically are small, but if you download a lot of them and/or a lot of hi-res photos or videos, this may be a consideration for you.
  - d. Set *Photos – Auto Purge Days* to your desired value. This purges photos only from your device, not from the portal.
8. If you haven't already completed the physical setup of your camera, skip to *Complete Physical Camera Setup* on page 6.

### Auto Setup

Now that you have connected your camera to the AT&T™ network, you are ready to complete the setup on your camera.

1. With the camera in SETUP mode, use the arrow buttons to navigate to the *Wireless* tab then to move through the submenu items.
  - a. *Send Mode*: select *Instant*, then specify the number of photos to send each day. Enter 0 if you want all photos sent.
  - b. *Send Via*: select *Auto*.



- c. With *Auto* selected for *Send Via*, move to *Recipient* then enter one destination email address. This may be either a regular email address or a device email address in the carrier's picture email format (e.g., 5555551212@vzwpix.com or 5555551212@mms.att.net). Note: While you can use your phone number email address, that is no longer recommended because some carriers have begun blocking some MMS messages and senders, which can result in your not receiving pictures from your camera. Spartan Camera does not guarantee the delivery of emails.
  - d. *Name Tag*: enter the name for your camera, up to 8 characters, that will appear on the picture info strip.
  - e. *Power Saving*: *On* provides longer battery life because the camera connects to the network only when it needs to send a photo or status report, *Off* provides slightly faster transmission speeds because the camera stays connected to the network all the time.
  - f. Press **OK** to save your changes.
  - g. Press **Menu** to return to the main menu.
2. Refer to *Manual Firmware Update* on page 8 and update your camera's firmware if necessary.
  3. Set the other parameters (Camera, Trigger, System) using the information in the tables starting on page 6. It is probably best to set the clock last.
  4. Once you have set all the parameters, press **Menu** to return to the *Preview* screen.
  5. When the camera shows that it is logged into the network, perform the "Hello test" to confirm that the camera is online.
    - a. Press **Menu**.
    - b. Scroll to the *Wireless* tab.
    - c. Under *Diagnostics*, select *Hello test* then press the **OK** button. If your camera is connected to the network properly, you will see the message *Success*.
  6. To test that the camera is taking and sending pictures properly, in *Preview* mode, press **OK** to take a picture then **OK** again to send it. If you are not setting up the camera to send pictures, you may want to test your camera using the instructions on page 8.

### Complete Physical Camera Setup

1. After setting up and testing the camera, position it on the target area and turn it on by sliding the power switch to ON. *Please remember to switch from SETUP to ON after the camera logs into the network.* The camera will take pictures or videos as programmed. The height you mount your camera depends on what your targets are, but 2-4 feet off the ground is generally best for wildlife, depending on what size animals you are want to photograph.

2. The green light on the front of the camera should flash for a few seconds to give you time to move out of the area. If it continues to flash for more than a few seconds, you have left the camera in *SETUP* mode rather than turning it *ON*.
3. *Important*: When you are ready to retrieve the SD card or change the settings, turn the camera off first by pushing the power switch to the OFF position.

Even in the OFF mode, the camera consumes a small amount of battery power. You should remove the batteries if the camera will not be in use for an extended time.

### Camera Settings

Press the **Menu** button to access the *Setup* menu. Navigate the menus using the following keys:

- Press ◀ or ▶ to move between the tabs (submenus).
- Press ▲ or ▼ move among the submenu items.
- Press ◀ or ▶ to change the value for an item.
- Press the **OK** button to save all changes you've made to settings in a tab.
- Press **Menu** return to the main menu (tabs) or to exit *Setup* mode (back one level).

Setting Items		Description	
CAM	Mode	Photo, Video, or Photo + Video.	
	Photo Size	3MP, 5MP, or 8MP.	
	Photo Burst	Set the number of images taken for each trigger (1-3). The camera will transmit all photos, not just 1, when burst is 2 or 3. (both Premium and Auto)	
Cam (cont'd)	Video Size	Transmittable with Premium, not transmittable with Auto or with Send OFF	
		320 * 200	5 Sec, 10 Sec
		1024 * 576	
	Not transmittable in any mode		
		720P (native)	1-30 seconds, selectable in 1-second increments.
	1080P (interpolated)		
	Video Length	5 sec, 10 sec (320*200 or 1024*576) 1-30 seconds, selectable in 1-second increments (720P, 1080P).	
	Sound	On/Off	

Setting Items		Description
Trigger	Sensitivity	Off (time lapse only, not triggered) Low (temps below 10° F.) Normal (10° F-80° F) High (temps above 80° F).
	Trigger Interval	Time between when a photo is sent and the next photo can be triggered. 0-55 seconds in 5-second intervals, 1-60 minutes in 1-minute intervals.
	Time Lapse	The camera will take pictures at specified intervals. When the camera is in Time Lapse mode, it also will be triggered by motion unless Sensitivity is set to Off. 30-55 seconds in 5-second intervals, 1-59 minutes in 1-minute intervals, 1-8 hours in 1-hour intervals.
	Start-Stop 1 & 2	The camera can be set to operate only during specific time periods. To enable this function, select <i>On</i> then press <b>OK</b> to access the start-stop menu. You can set one or two start/stop intervals. For each, you can set start and stop times, trigger interval, and time lapse interval. The trigger intervals and time lapse intervals are the same as for the regular Trigger Interval and Time Lapse settings. The start-stop setting will override all other general camera settings. If you set two start/stop times, make sure that the times do not overlap.

Setting Items		Description
SYS	Clock	Set the date and time. If you want the photos to be date and time stamped correctly, you must set the clock for Auto or regular trail camera mode. If you are using Premium, set the time zone from the app or web portal and the camera will maintain date and time by getting it from the server.
	Time Stamp	On if you want the photo info strip to show the date/time, Off if you don't.
	Flash Power	High (distances greater than 15 feet) Low (distances of 15 feet or less)
	Format	Format the SD card. (This will erase all data on the SD card and cannot be undone.)
	Overwrite	On or Off. The On setting sets the camera to delete the oldest photo/video to write the newest if the SD card is full. If this is set to Off, the camera will stop taking pictures or recording videos when the SD card is full.

Setting Items		Description
SYS (cont'd)	Default	Restore all settings to factory default values.
	Information	Show hardware and firmware versions and IMEI.
	Password	Set a 6-digit password.
	Beep	On/Off
	FW Update	Manual firmware update from SD card
LED Indicator	On/Off	

Setting Items		Description
Wireless	Send Mode	Instant (send photo instantly) Off (camera functions as a regular trail camera).
	Send Via	Premium or Auto.
	Recipient	Input the one recipient email address. (Auto only, use the web portal for Premium.)
	Name Tag	Up to 8 characters to appear on the photo info strip. (Auto or regular trail cam mode. For Premium, use the app or portal.)
	Encrypt Picture	(Premium only) With encryption <i>On</i> , all images will be delivered encrypted. In order to decrypt and view these images, you must use the Wireless Encrypted Image Viewer (Microsoft Windows only), which you can download from <a href="https://www.spartancamera.com/download">https://www.spartancamera.com/download</a>
	Register Camera	(Premium only) Get the registration code needed to add the camera to your account on the web portal.
	Power Saving	On to conserve power, photo delivery takes a few seconds longer because the camera only goes online to send a photo or status report; Off for slightly faster photo delivery but shorter battery life because the camera stays online all the time.
	Diagnostic	<i>Hello Test</i> (to test connectivity) <i>Camera MDN</i> (to see the camera's phone number) <i>Module FW Update</i> <i>Module FW Version</i>

## Test the Camera

### Photo, instant send mode

1. Press the **OK** button to take a picture.
2. Press the **OK** button to send the picture to the portal/app (Premium) or recipient programmed into the camera (Auto) or the **Menu** button not to send the photo.

### Photo, daily report or send mode off

1. Press the **OK** button to take a picture.
2. Review the picture using the instructions that appear later in this section.

### Video

1. Press the **OK** button to start recording a video. The camera will record video until you stop it or it runs out of storage space on the SD card; the video length you set does not apply to manually-recorded videos.
2. Press the **OK** button to stop recording the video.
3. Review the video using the instructions that appear later in this section.

### Access Photos or Videos

1. With the camera in *Preview* mode, press the playback button ► to switch to *Playback* mode to view photos or videos.
2. Use ◀ or ▶ to move through the photos or videos.
3. Press the playback button ► again to exit *Playback* mode. Press **OK** to start playing the video clips.
4. Press **OK** to stop playing and return to playback mode.

### View a Photo

While viewing a photo, use ▲ to zoom in and ▼ to zoom out. While zoomed in, press **OK**, then use ▲▼◀▶ to pan the zoomed image.

### Watch a Video

While viewing the opening frame of a video, press **OK** to play/pause the video.

### Delete Photo or Video

1. While viewing a photo or video:
  - a. Press **Del** to delete the current photo or video or
  - b. Press **Menu** to be able to select either *Del One* or *Del ALL*.

2. Press ◀ or ▶ to select *Yes* or *No*, then press **OK** to execute (perform the deletion) or **Menu** to exit without deleting. Warning! Deleted *files cannot be recovered!*

## Manual Firmware Update

If you are using Premium, the easiest way to perform a firmware update is Over The Air (OTA): *MY CAMERAS > FIRMWARE UPDATE*, then click the *Update* button. The FW should update after the next time the camera contacts the server to send a photo, video, or status report.

To perform a manual firmware update (Auto or if you are using Premium but can't or don't want to use OTA):

1. With your camera in *SETUP* mode, on the *System* menu, scroll down to *Information*, press **OK**, and note the date of the FW Ver.
2. Using your computer, go to [www.spartancamera.com](http://www.spartancamera.com).
3. *SUPPORT > FIRMWARE / SOFTWARE*
4. If the date of the firmware on the web portal is more recent than the date of the FW in your camera, click the *Download* button beside the camera model and save the file to your computer. Make sure you choose the correct model.
5. With an empty SD card (preferably one that was formatted in your camera) in your computer's SD card reader, copy the file from your computer to the SD card. It should not be inside any folder on the card.
6. Insert the SD card back into the camera.
7. To apply the firmware, with the camera in *SETUP* mode:
  - a. Press the **Menu** button.
  - b. On the *System* tab, select *FW Update*, press **OK**, select *Yes*, press **OK**, then watch the screen for progress. When the FW update is complete, the camera will restart.
8. Reload the camera defaults:
  - a. Press the **Menu** button.
  - b. On the *System* tab, select *Default*, press **OK**, then select *Yes*.
9. On the *System* tab, choose *Information* and verify the firmware version has changed.
10. Reset your camera's settings. If you are using Premium, request a setting update on the app or portal, then take and send a manual photo. If you are not using Premium, reset your settings using the camera's menus.

### Technical Specifications

Picture Resolution	3 MP / 5 MP / 8MP
Video Resolution	320*240@30 fps 1024*576@30 fps 720p@30fps 1080p@10fps
Delivery Options	Premium, Auto, None (Send Off)
Transmitted Images	Thumbnails: 640*480 or 1280*960 HD (upon request): 2048*1536 (3 MP) 2592*1944 (5 MP) 3264*2448 (8 MP)
Transmitted Videos	320*240@30 fps 1024*576@30 fps
Trigger Time	0.6s
Lens	FOV (Field of View) = 52°
Night Illumination	InfraRed Blackout Flash
Display Screen	2.0" LCD
Memory Card	up to 32GB
Trigger	Motion (PIR) / Timer (Time Lapse, Start-Stop)
PIR Sensitivity	Adjustable (High/Normal/Low/Off)
Temperature	-4 - +140F (Operation) -22 - +158F (Storage)
Trigger Interval	0s - 60 min
Time Lapse Interval	5s - 60s/1 min - 60 min/1 hr - 8 hrs
Photo Burst	1 - 3
Video Length	5s, 10s (320*240, 1024*576)—transmittable via cellular network 1 - 30s (720P, 1080P)—not transmittable
Power Supply	4, 8, or 12 1.2-1.5v AA alkaline, lithium, or NiMH optional: 6V external power, AC power
Stand-by Current	< 0.20 mA (< 5 mAh/day)
Sound Recording	Available
Mounting	Tripod / mounting strap / Python lock
Weight	0.8 lbs
Dimensions	6 x 5 x 3.5 inches
Operation Humidity	5% - 90%

### Manufacturer Limited Warranty

#### Terms and Conditions

Spartan Camera (SC) warrants our Spartan Camera products against defects in material or workmanship for a period of two years from the original date of purchase of the product by a consumer (the "Warranty Period"). If a material or workmanship defect arises with regard to any Spartan Camera, and a valid claim is received within the Warranty Period, SC will (1) repair the camera using new or refurbished parts or (2) replace the camera with a new or refurbished product. For purposes of this limited warranty, "refurbished" means a product or part that has been substantially returned to its original specifications. In the event of a defect, these are your exclusive remedies. The warranty on any replacement product provided under this warranty shall be for the unexpired portion of the warranty period applicable to the original product.

The warranty agreement, as defined here, is the sole controlling terms. No other warranty information as published by SC, relating to other products, applies to the Spartan Camera series.

#### Shipping

Initial shipping of items to SC for warranty coverage is the responsibility of the customer. SC has no responsibility for any items lost or damaged during incoming shipment. It is recommended that all shipments made by the customer be insured. Before shipping any items for warranty coverage, an RMA must be obtained via phone or the SC website. Any items received without a valid RMA may result in delays in service or loss of the item. If your RMA is approved, your RMA number is only valid for 30 days from the date of issue, and only for items originally listed on the RMA request form. In addition SC reserves the right to charge a small shipping and handling fee in connection with the fulfillment of any valid claim. Please include \$11.95 for return shipping & insurance. (For U.S. customers only. CHECK OR MONEY ORDER ONLY, NON-REFUNDABLE). International customers pay different amount of shipping & insurance. We will send detailed information along with the RMA number.

#### Proof of Purchase or Proof of Warranty Coverage

We pride ourselves on providing top-quality scouting cameras for your hunting, research and security needs, and take quality seriously. We are constantly

evolving our designs to ensure our products do the best job possible. When requesting warranty coverage, we may require the following:

- a) Warranty registration within 30 days of the original purchase date, via mail in warranty card or online at the SC website is **required** for warranty coverage to be valid.
- b) We may require proof that the claim is valid. In this regard, we may ask you to, for example, trouble shoot service issues via phone, e-mail or other electronic means, return your product to us for warranty coverage verification, or provide such other proof to allow us to determine the validity of warranty coverage on your claim. This most likely will require you to send your product in to us.
- c) We may require you to provide us with your purchase receipt as proof of purchase from an authorized dealer.

### **Exclusions and Limitations**

Except for the limited warranty expressly set forth above or to the extent restricted or prohibited by applicable law, SC expressly disclaims any and all other warranties express or implied, including any warranty of quality, merchantability, or fitness for a particular purpose, and you specifically agree that SC shall not be liable for any special, incidental, indirect, punitive, or consequential damages for breach of any warranty of any type on any SC product.

In addition to and without limiting the generality of the foregoing disclaimers, the limited warranty does not, under any circumstances, cover the refund or reimbursement of the cost of any wireless data charges incurred while warranty services are being rendered. Wireless data plan management is solely the purview of the account holder and should be managed accordingly if warranty service is necessary.

Warranty coverage is specifically limited to the original purchaser of the product and does not extend to any subsequent parties. Warranty coverage is exclusively limited to purchases made through an authorized dealer or retailer.

The refurbished item will carry, (1) the remaining balance of the warranty period of the original warranted item, (2) 90-day limited warranty, which ever is longer. The repair or replacement does not extend the original warranty period.

This warranty is void if the product housing has been removed, if the product's label, logo or serial number has been removed.

The following item are expressly excluded from warranty coverage:

- Any damage, malfunction or degradation of performance resulting from use of the product in an environment not meeting the operating specifications

set forth in the user manual. Spartan Cameras are very water resistant; however they are not water proof.

- Any damage, malfunction or degradation of performance resulting from failure to properly prepare and transport the product as prescribed in published product materials
- Any damage, malfunction or degradation of performance resulting from improper use or connection to incompatible batteries, power supplies or memory.
- Any damage resulting from attempts by personnel other than SC representatives to install, repair or service the product unless directed by a SC representative.
- The replacement of items that have been abused, misused, or tampered with in any way.
- The repair of an item that has been modified or integrated with other products when the effect of such modification or integration increases the time or difficulty of servicing the product or degrades performance or reliability.
- The performance of software or firmware updates or upgrades.
- The correction of user programing errors.

### **Unclaimed Items**

It is the customer's responsibility to respond to any inquiry initialized from our warranty department. SC will only keep the returned goods for 6 months. Unclaimed returned item(s) will be discarded after 6 months.

If the product is beyond the warranty period, the price for repairing or replacing may vary. Please allow 6-8 weeks for delivery.

### **Camera Repair**

There will be a charge for repairs not covered by the. Please contact HCO Outdoors to determine more information and to discuss repair options not covered under warranty.

### **Privacy Policy**

Thank you for visiting [www.spartancamera.com](http://www.spartancamera.com) (the "Site") and reviewing the Privacy Policy of [spartancamera.com](http://www.spartancamera.com). ("SC" or "we" or "us"). It is important to us that you understand what information we collect when you visit the Site either from a computer or a mobile device as well as any information that is uploaded to the site by your cameras. Herein we describe what we may do with that information for you below. This Privacy Policy also covers the collection of data from applications on mobile devices.

By using this Site you consent to the terms of this Privacy Policy, and you signify your assent to all of the terms of this Privacy Policy and our Terms of Use. If you do not agree with any terms of this Privacy Policy or our Terms of Use, please do not use this Site or submit any personal information. Please take care to read our Privacy Policy to be sure you are informed about how your information may be used. Please also read our Terms of Use.

### How Do We Use Your Email Address?

Spartan Camera will use your email address to contact you to manage your account. For example, we may contact you via email in cases where your account has zero premium credits and you have active expiring camera as a convenience as well as error conditions relating to camera operation or wireless service issues. The web portal also allows you to maintain an email contact list for the delivery of photos and status reports. These emails and delivery functions are under your control. We do not share your account email or email contacts publicly or with any other parties under any circumstances.

### Do We Use Cookies?

We use HTTP (or HTML) cookies to collect non personal information, to help remember you on future visits primarily. In the event of a site shopping cart then a cookie may also be required for an eCommerce purpose.

### Security Measures

While Spartan Camera has security measures to help protect the information under our control, no data transmission over the Internet or any wireless network can be guaranteed to be 100% secure.

- SC tries to protect your personal information and ensure the security of your communications on our systems, by maintaining physical, organizational and technological safeguards (appropriate to the sensitivity of such information) designed to protect it against unauthorized use, disclosure or access of the personal information we collect on this Site. However, we cannot ensure or warrant that any information you transmit to us will stay safe and secure and you do so at your own risk.
- Your information may be stored in whole or in part on equipment or in facilities leased or licensed from others. Although SC tries to keep your information safe, it relies on the statements of those vendors regarding the safety and security of their storage equipment and services as part of its evaluation. By using the Site, you agree that SC is not responsible if the storage equipment and services provided by others are not

working like they are supposed to, and that you will have to seek any remedies from those providers, not SC.

### Retention and Deletion

We keep your personal information only so long as we need it for the purposes for which it was collected, for the products and services that you are using, or to meet any legal requirements. We have retention standards, which meet these requirements. We destroy your personal information when it is no longer needed. Photo uploads by your camera devices are currently maintained for a 30 day period. Each night photos that are 30 days or older are purged from the server. We urge you to maintain your own backups of your images based on your particular needs.

### Terms of Use

The latest terms and conditions are available at [www.spartancamera.com/privacyterms](http://www.spartancamera.com/privacyterms).

Thank you for visiting [www.spartancamera.com](http://www.spartancamera.com) (the "Site"), operated by SpartanCamera.com, Inc. ("SC" or "we" or "us"). Please carefully read these Terms of Use ("Terms") so you understand how we operate this Site, what we can offer and how we can work together. Please also read our Privacy Policy. By using the Site and the SC Services, you are agreeing to the Terms and Privacy Policy posted at the time of your visit.

### About Us

Spartan Camera offers the Web Portal and associated Mobile Applications which are used to provide a premium function for the line of wireless cameras.

### Our Customers

The Site is open to anyone, but some of the SC Services are only available to registered members ("Members"). You can visit the Site without registering and we will consider you a "User."

### Membership Responsibilities

When you become a Member, you agree to the following:

- You have provided true information when you registered to be a Member;
- You have given us a valid email address, and we may confirm upon registration, or at any time thereafter, via a confirming e-mail which may require a response to complete your registration or keep it active;

- You will notify us if something changes;
- You are not breaking any laws when you use the SC Services; and
- You will not violate these Terms as a Member.

If you become a Member, you are responsible for the Content and activities in your account, for protecting your Content with a secure password and not sharing your password with anyone. We recommend using a combination of numbers, symbols and lower and upper case letters to create a secure password.

Spartan Camera reserves the right to terminate your Membership at any time (even if you've paid), without warning for any or no reason, with or without prior notice or explanation and without liability, and can even take legal action if needed.

For example, please note that it is our policy to terminate the accounts of Members who repeatedly infringe the intellectual property rights of others. We have a similar policy for Members who violate these Terms or commit illegal acts using the Site or Spartan Camera Services—although we may, in our discretion, instead deny, restrict or suspend access to all or any part of the Site or Spartan Camera Services or terminate a Member's account when something similar occurs.

You may cease use of the Services at any time. Even after you are no longer a Member, you will still be responsible for the promises you have made to us about your Content (defined below). You will be responsible for any damages that result from your breaking those promises as further outlined below.

### Cost and Pricing

- Visiting: There is no cost to visit the Site or to register as a Member.
- Free Credit: Each newly registered Spartan GoCam camera will add one free credit to your account providing full use of the portal services for one month for one camera. This is not applicable to all models.
- Premium Service: These are in the form of monthly credits that you purchase online. A monthly credit will provide for a single camera to operate for one month on the web portal and in conjunction with our free mobile applications. If you are a user of one of these services, we consider you a "Paying Member." All Terms apply unless explicitly stated.

### Content Limits

Spartan Camera continues to grow and get better because of users like you (Thank you!). Each camera that consumes a monthly Premium Service credit is provided with one month of photo uploads and other real time interactions

using the web portal and mobile applications. Photos are maintained on our server for up to 30 days before they are individually purged. There are no restrictions on the number of photos a camera can upload including thumbnails and high res images during the 30 days of operation. Your device wireless plan covers the bandwidth used and your Premium Credit provides complete use of the portal and mobile apps for your active devices.

### Content & Privacy

You retain all your rights to any Content you submit, upload or display on or while using Spartan Camera services. This means that you own all the Content you post and are responsible for its settings:

- Your content is considered private and not visible to other users or the public internet.
- It is considered a misuse of the Premium Service to provide your user credentials publically and doing so may result in termination of your account and removal of your content.
- Providing direct links to your content is also prohibited.
- By allowing your camera to upload photos, you are confirming that the Content is yours—no one else's—and that the uploading and use of your Content does not violate the privacy rights, publicity rights, copyrights, contract rights, intellectual property rights or human rights of somebody else. If we learn that you are infringing others' rights or are using Content that is not yours, SC has the right to remove this Content and you agree that you are responsible for any costs associated with the infringement.
- SC may moderate Content. However, we are not responsible for what you have uploaded and we are under no obligation to modify or remove any inappropriate Content.
- If you stop using the Spartan Camera Services, your Content may remain on the Site unless you actively remove your Content. Photos will be purged after a 30 day retention period automatically.
- In order to continue to improve the Site and SC Services, we may use software and other things on the Site that we own or that have been licensed to us ("Spartan Camera Software"). Spartan Camera has also created the look, feel and architecture of the Site and has posted certain images and videos ("SC Content"). Together the SC Content and SC Software are the "SC Materials." SC Materials are ours and remain ours. Except in viewing the Site, you agree that you will not copy, distribute, publicly perform, publicly display, reproduce or create derivative works from the SC Software.

- Our Webmaster and IT technicians reserve the right to investigate issues or problems on our server during the course of normal operation. This may mean that your content is visible to us during the diagnosis of said problems. We will take every precaution to maintain the privacy of your content at this time. If you are involved in a technical issue with the site software, it may be necessary to study your account settings and content during the diagnosis of the issue.

### Limits on Use

- It is a violation of these Terms to disrupt the Site or the way it functions, interfere with other Users' enjoyment of the Site or Spartan Camera Services or use the Site to deceive, harass or solicit people.
- It is also a violation to scrape the Site, fuser files or otherwise make any use of data mining, robots or similar data gathering and extraction tools.
- It is up to Spartan Camera whether to terminate your use for violation of these prohibitions or similar activities.

### Other Important Guidelines

- These Terms and the Privacy Policy can change. Again, please carefully read this document and our other policies. We may announce if any "big" changes are made, but so long as you've used the Site after the change, regardless of any separate notice, you agree to the current posted version of the Terms.
- Our Site is hosted in the US. There may be more or fewer protections for you in your country than here.
- Software available in connection with the Site and services offered through the Site (the "Software") is further subject to United States export controls. No Software may be downloaded from the Spartan Camera Services or otherwise exported or re-exported in violation of U.S. export laws. Downloading or using the Software is at your sole risk.
- These Terms are governed by, and interpreted in keeping with, the laws of the State of Georgia, regardless of any conflict of law provisions. You and Spartan Camera agree to submit to the exclusive jurisdiction of the courts located within the State of Georgia to resolve any dispute arising out of the Agreement or the Spartan Camera Services. YOU AND Spartan Camera HEREBY EACH KNOWINGLY, VOLUNTARILY AND INTENTIONALLY WAIVE ANY RIGHT IT MAY HAVE TO A TRIAL BY JURY IN RESPECT OF ANY LITIGATION (INCLUDING BUT NOT LIMITED TO ANY CLAIMS, COUNTERCLAIMS, CROSS-CLAIMS, OR THIRD PARTY CLAIMS) ARISING OUT OF, UNDER OR IN

CONNECTION WITH THIS AGREEMENT. FURTHER, EACH PARTY HERETO CERTIFIES THAT NO REPRESENTATIVE OR AGENT OF EITHER PARTY HAS REPRESENTED, EXPRESSLY OR OTHERWISE, THAT SUCH PARTY WOULD NOT IN THE EVENT OF SUCH LITIGATION, SEEK TO ENFORCE THIS WAIVER OF RIGHT TO JURY TRIAL PROVISION. EACH OF THE PARTIES ACKNOWLEDGES THAT THIS SECTION IS A MATERIAL INDUCEMENT FOR THE OTHER PARTY ENTERING INTO THIS AGREEMENT.

- As a Member of SC Services, if you become aware of misuse of the SC Services by any person, please email [abuse@spartancamera.com](mailto:abuse@spartancamera.com) and include a sample of the misuse.
- You use the Site at your own risk and the Site and services are provided "AS IS."
- We are not saying that the Site will meet any of your specific needs or that you will get any particular results if you use the Site. We are not responsible for the conduct of other Users' conduct on- or off-line.
- We encourage you to always keep backups of your Content. Spartan Camera is not responsible if any of your Content is deleted, or if any modification, suspension or discontinuation of the Site or services causes you to lose any Content—even if you're a Paying Member.
- While we make an effort to keep the Site up and running at all times, we are not responsible for any errors, omissions, interruptions, deletions, defects, delays in operation or transmission, communications line failure, theft or destruction or unauthorized access to, or alteration of, any User communication, whether the result of our maintenance of the Site or any problems or technical malfunction of any network, servers, software or equipment, Internet traffic or any other failure of any nature.
- We are not responsible for advertisements or applications or services that are posted on or through the Site, nor do we have any responsibility for the goods or services provided by our advertisers or via other websites or applications, including our print vendor.

### Things to Keep in Mind

Though everything in these Terms and in our Privacy Policy is a binding contract, we need to let you know the following:

- Limitation on Liability. IN NO EVENT SHALL Spartan Camera BE LIABLE TO YOU OR ANY THIRD PARTY FOR ANY INDIRECT, CONSEQUENTIAL, EXEMPLARY, INCIDENTAL, SPECIAL OR PUNITIVE DAMAGES, INCLUDING LOST PROFIT DAMAGES ARISING FROM YOUR USE OF THE Spartan Camera SERVICES, EVEN IF Spartan Camera HAS BEEN ADVISED OF THE POSSIBILITY OF SUCH DAMAGES.



NOTWITHSTANDING ANYTHING TO THE CONTRARY CONTAINED HEREIN, GOWIRELESS'S LIABILITY TO YOU FOR ANY CAUSE WHATSOEVER AND REGARDLESS OF THE FORM OF THE ACTION, WILL AT ALL TIMES BE LIMITED TO THE AMOUNT PAID, IF ANY, BY YOU TO Spartan Camera FOR THE Spartan Camera SERVICES DURING THE TERM OF MEMBERSHIP.

- **Your Indemnity to Us.** If you breach any of the representations made herein regarding your rights in the Content, or your uploading of Content violates any of the promises you have made, you agree to indemnify, defend and hold Spartan Camera, its subsidiaries, and affiliates, and their respective officers, agents, partners and employees, harmless from any loss, liability, claim, or demand, including reasonable attorneys' fees, made by any third party due to or arising out of your use of the Site and Spartan Camera Services in violation of that and/or arising from any Content that you post on or through the Site and Spartan Camera Services.
- **Some Obligations Continue Even After You've Gone.** Even if you close your account or we terminate your Membership, you will still be responsible for indemnifying us for breaches that took place while you used the Site and Spartan Camera Services. Obligations you owed to us and Users of the Site, which by their nature are intended to survive closing or termination, will survive.

### Image Delivery

- In order to comply with Internet and server protocols, any account that attempts to send images to an email address which repeatedly "bounces" or returns image messages as undeliverable will be blocked from service. Any email address associated with an account that results in a spam or violation of service report against Spartan Camera servers will be blocked from service.
- Due to the nature of image transmission via wireless networks, Spartan Camera is not responsible for delays in, or reception of, images transmitted by any Spartan camera.
- If you are using an MMS-to-email service provided by your wireless carrier and that service is discontinued or eliminated by your carrier, Spartan Camera is not responsible for the lack of this service or bound to provide a replacement.
- Spartan Camera reserves the right to make changes to Premium Service without notice.

The information in this document is subject to change without notice and should not be construed as a commitment by Spartan Camera. Spartan Camera assumes no responsibility for any errors that may appear in this document.

In no event shall Spartan Camera be liable for incidental or consequential damages arising from use of this document or the software and hardware described in this document.

This document and parts thereof must not be reproduced or copied without Spartan Camera written permission, and contents thereof must not be imparted to a third party nor be used for any unauthorized purpose. Contravention will be prosecuted.

Additional or updated copies of this document may be obtained from the Spartan Camera website.



**S P A R T A N**  
**C A M E R A**

**Customer Service Contact**

E-mail: [support@spartancamera.com](mailto:support@spartancamera.com)

Website: [www.spartancamera.com](http://www.spartancamera.com)

Phone: 1-770-582-0004

6665 Corners Industrial Ct. Suite D

Norcross, GA 30092

U.S.A.